



Excellent manoeuvrability in the most congested areas

- Proportional controls provide for smooth and progressive movements
- Narrow turning radius
- Vertical jib allowing better accessibility to the work area (3m outreach)

Optimal productivity

- Driveable at full height
- Low machine weight means longer working cycles

Robust, reliable, easy to maintain





STAR 8 / STAR 10

VERTICAL MASTS

TECHNICAL DATA

	STAR 8	STAR 10
Working Height	8.2 m	10 m
Platform Height	6.2 m	8 m
Horizontal outreach	3 m	3 m
Lift capacity	200 kg	200 kg
Platform size	0.78 x 0,99 m	0.78 x 0,99 m
D Length	2.7 m	2.7 m
B Width	1 m	1 m
A Height - stowed	1.99 m	1.99 m
Tailswing	0 cm	0 cm
C Wheelbase	1.2 m	1.2 m
E Ground Clearance	10 cm	10 cm
Driveable at full height up to	6.2 m	8 m
Drive speed proportional	0.6 - 4.5 km/h	0.6 - 4.5 km/h
Turning radius - outside	1.88 m	1.88 m
Turntable rotation	345°	345°
Vertical jib rotation	130° (+70/-60)	130° (+70/-60)
Tires - non marking	16x5x10.5	16x5x10.5
Tilt alarm	3°	3°
Gradeability	23 %	23 %
Hydraulic system capacity	7 l	7 l
Power source	24 V - 240 Amph	24 V - 240 Amph
Weight	2610 kg	2735 kg

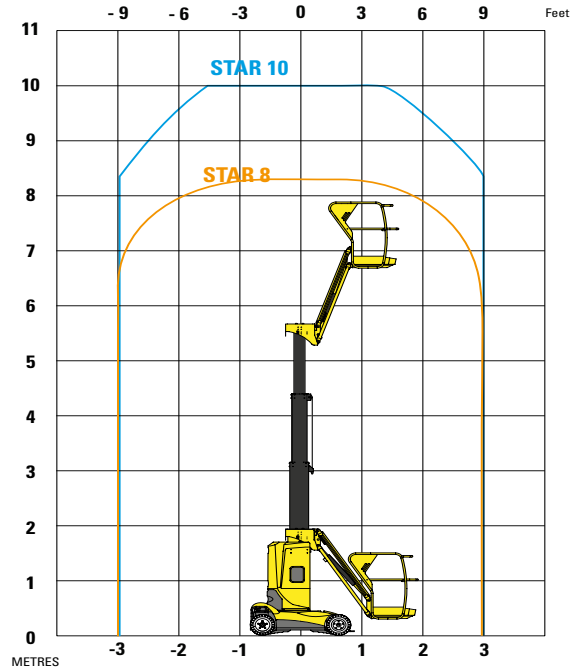

STANDARD EQUIPMENT

- 24 V Electric motor
- 24 V – 240 Ah traction batteries
- 30 Amp battery charger
- Battery charge indicator
- Fixed potholes
- 2 drive speed
- 2 rear steering wheels
- 2 front driving wheels
- Non-marking tires
- Brake release
- Hourmeter
- Horn
- Emergency stop buttons at cage and ground level
- Load controller in the platform
- Emergency hand pump
- 2 control stations at cage and ground level
- Fixed control station in the platform
- 2 rings in the platform for safety harnesses
- Towing hooks and lifting eyes

OPTIONS AND ACCESSORIES

- Power line in platform
- Maintenance-free batteries
- Centralised battery filling
- Travel alarm
- Flashing light
- Working light
- Air line in platform
- Cold Weather Package
- Biodegradable oil

